



SAMPLER
includes three full units

WELCOME TO OUR WORLD

Bringing the World to the Classroom
— and the Classroom to Life

NGL.Cengage.com/ourworldtours

WELCOME TO OUR WORLD

Introduction 1
 Songs 2
 Learning Materials 4
 Professional Development 6
 Online Support 8
 Series Editors 9



STUDENT BOOK 1

Unit 8 Look at the Bug! 10



STUDENT BOOK 2

Unit 4 Animals on a Farm 18



STUDENT BOOK 3

Unit 4 Singing and Dancing 26

To access audio and video samples, please visit NGL.Cengage.com/ourworldtours

Learn English with songs performed by young learners around the world.



Professional Development video helps teachers use the songs and games effectively.



BRINGING THE WORLD'S SONGS TO THE CLASSROOM – AND THE CLASSROOM TO LIFE

Welcome to Our World is a three-level preprimary series in American English. It uses traditional children's songs from around the world, with amazing National Geographic photos and images, to introduce very young learners to the world of English.



Beautiful photos capture the imagination of very young learners.

7 I'm Happy

6 Story Time

a castle

3 Make a bean shaker.

4 Make a duck mask.

Games and activities make learning English fun!

SONGS FROM AROUND THE WORLD

Welcome to Our World introduces very young learners to traditional children's songs from around the world, teaching them English through music, rhythm, and motion. Each song is performed by young learners in real classrooms and taught by Dr. Joan Kang Shin, and fully supports the language and concepts introduced in the Student Books.



Teaching Support

To help teachers use the songs confidently in their classrooms, Teacher Video is provided, hosted by Dr. Shin, with step-by-step instructions for teaching each song to their young learners.

Song Overview
Learn about the songs and watch young learners perform them in their native language.



Learn the Gestures
See Joan demonstrate how to perform the song gestures.

Teaching the Song
Listen to Joan explain how to teach the songs to young learners.

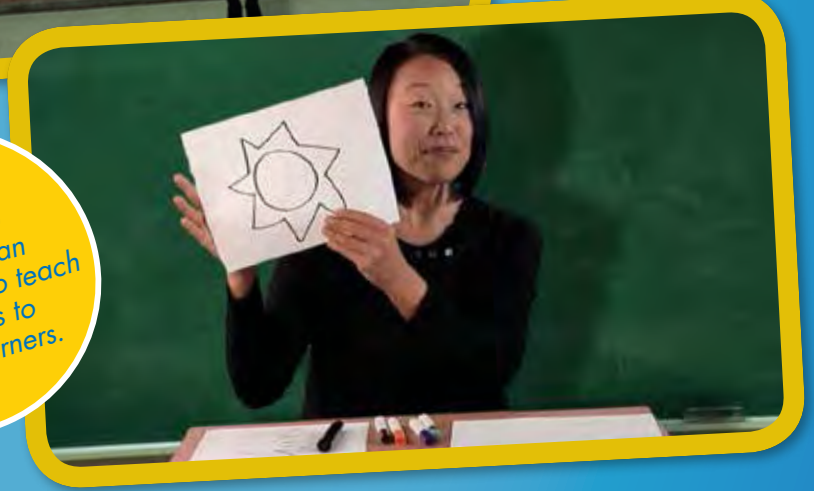

LEARN ENGLISH WITH NATIONAL GEOGRAPHIC

Welcome to Our World uses beautiful photography, songs, and games to capture the imaginations of very young learners and introduce them to the world of English.



Each level of *Welcome to Our World* includes:

- Traditional songs from around the world
- Vocabulary presentation and review
- Relevant content and topics
- Opportunities to hear and repeat target language
- Fun games and activities
- Classroom video hosted by Dr. Joan Kang Shin

8 Boats, Cars, Bikes



Vocabulary Presentation 63

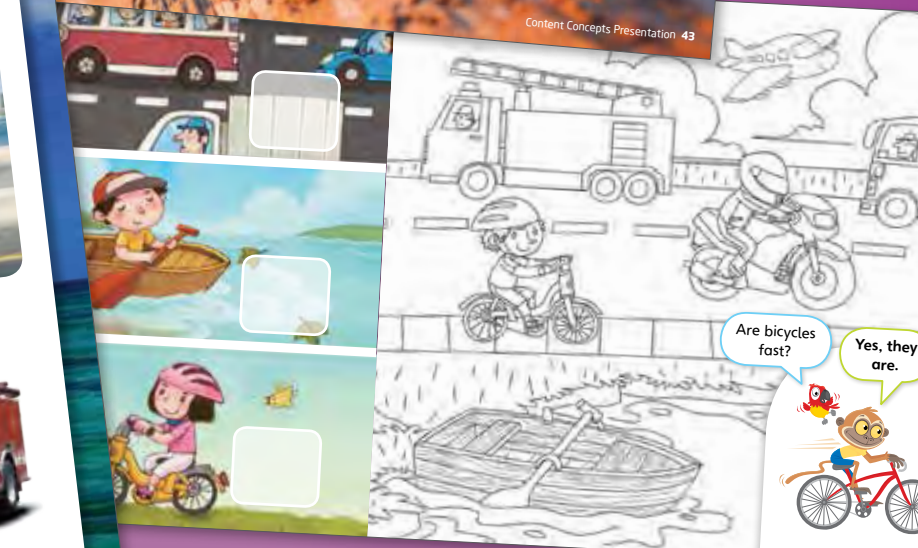

PROFESSIONAL DEVELOPMENT FOR EVERY TEACHER



To ensure teachers are fully supported in their young learner classrooms, the Teacher Video also includes a series of Professional Development videos, with best practices for teaching English successfully using songs and games with *Welcome to Our World*.

Hosted and developed by Dr. Shin,
the videos include:

- Using songs with very young learners
- Adapting songs to different cultures
- Keeping students' attention
- Using hands-on games
- Making and using puppets
- Additional songs for classroom management



ONLINE SUPPORT WITH myNGconnect

myNGconnect is an online companion site for teachers and parents, and provides easy access to resources that support, reinforce and build on the learning done in the classroom.



With myNGconnect, teachers and parents have access to:

FOR LEARNERS

- Student Video
- Activity Book Audio

FOR TEACHERS

- Teacher Video
- Classroom Audio
- Activity Book Audio
- Assessment Resources
- And more!



MATERIALS FOR TEACHERS AND LEARNERS

All three levels of *Welcome to Our World* are fully supported with materials that ensure teachers can effectively and confidently teach the vocabulary and concepts necessary to introduce very young learners to the world of English.



FOR LEARNERS

- Student Books, with Student Video DVD
- Activity Books, with Audio CD
- Online Student Resources, powered by myNGconnect

FOR TEACHERS

- Lesson Planners, with Teacher Video DVD, Classroom Audio CD, and Teacher's Resource CD-ROM
- Teacher Video DVDs
- Classroom Audio CDs
- Big Books
- Poster Sets
- Picture Card Sets
- Online Teacher Resources, powered by myNGconnect

SERIES EDITORS



Dr. Joan Kang Shin

Dr. Joan Kang Shin is the Director of TESOL Professional Training Programs in the Education Department at the University of Maryland, Baltimore County, and specializes in the training and professional development of teachers of English to young learners. In her role she is responsible for administering professional development and teacher training programs that reach teachers in over 100 countries around the world.



Dr. JoAnn (Jodi) Crandall

Dr. JoAnn (Jodi) Crandall is Professor Emerita and former Director of the Language, Literacy and Culture Ph.D. Program, and Co-Director of the MA TESOL Program at the University of Maryland, Baltimore County. She has worked in all areas of ESL/EFL including teaching, curriculum and materials development, standards development and teacher training.

Also from the Series Editors

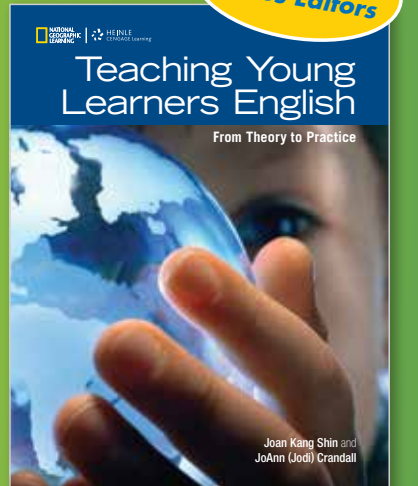

NGL.Cengage.com/tyle

NGL.Cengage.com/ourworldtours



8 Look at the Bug!



the sun



a tree



a flower



grass

a bug





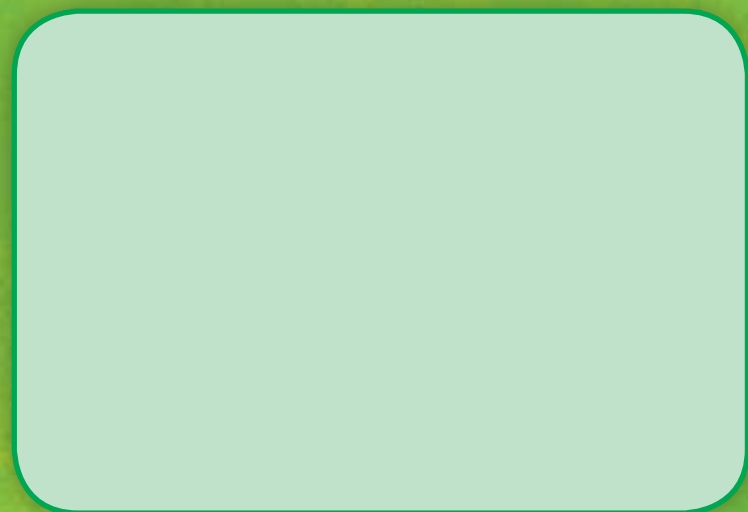
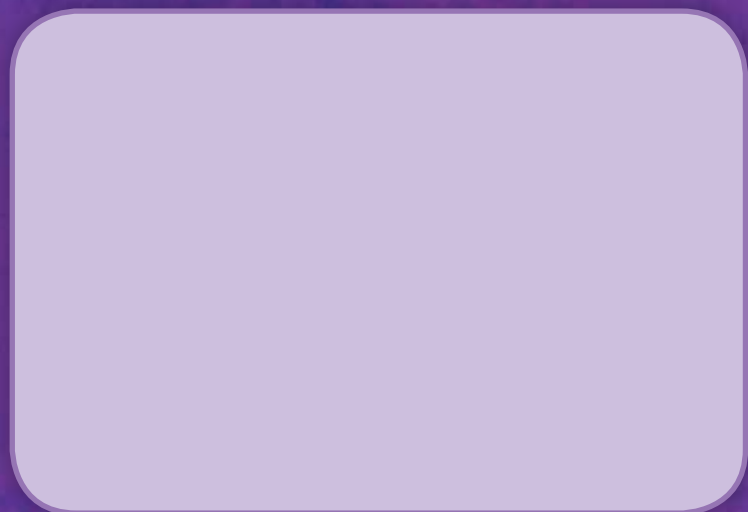

Look at
the flower!



4 Animals on the Farm



a chicken



a cow



a horse



a donkey



a duck



a goat





6



7



How many horses are there?

There are 3 horses.



4 Singing and Dancing



singing



clapping



stomping



dancing



shouting



a drum



a guitar



a piano

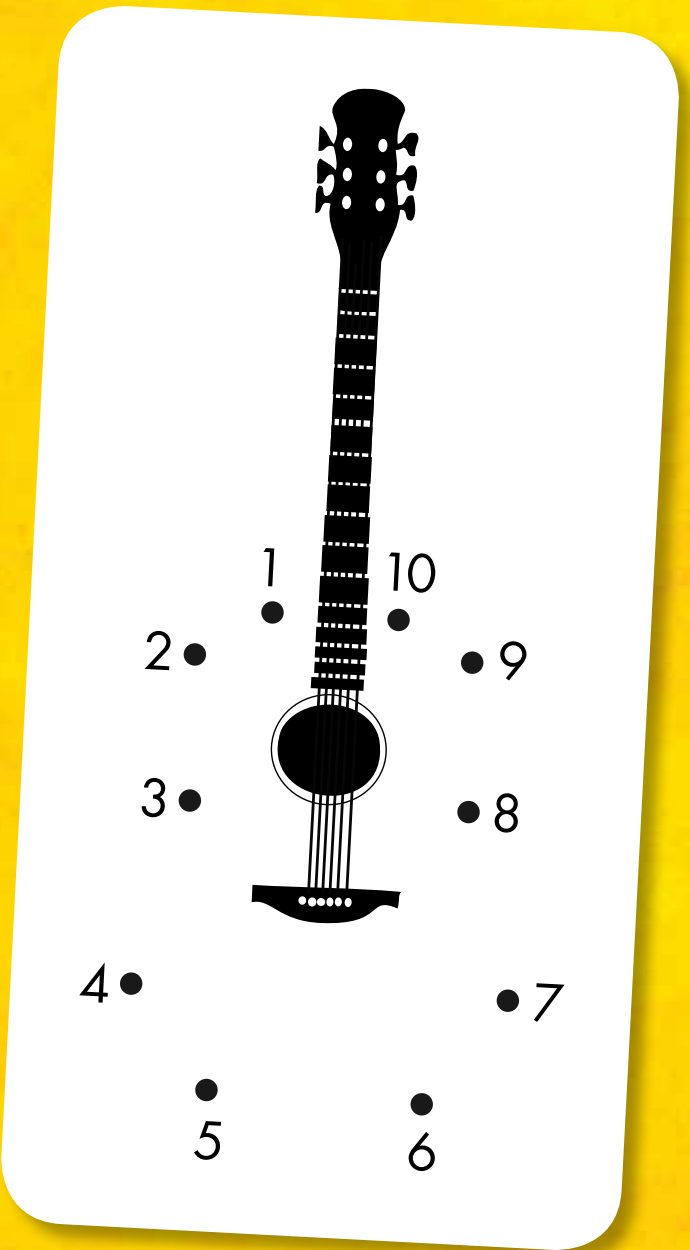
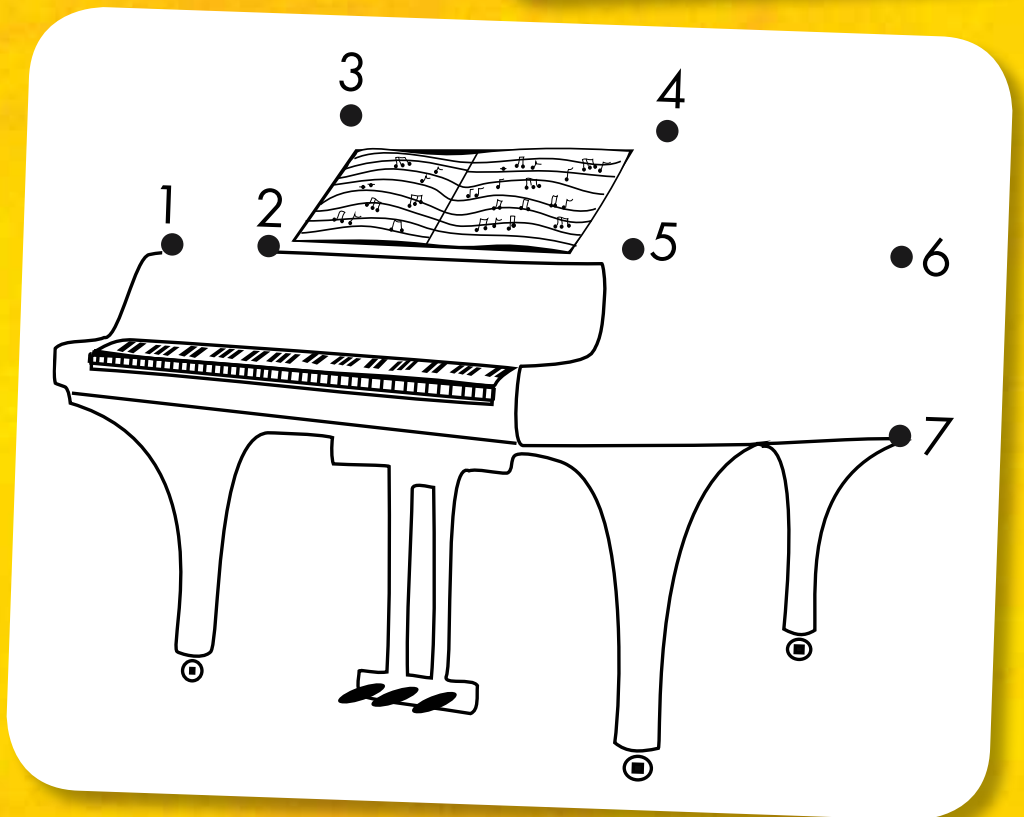
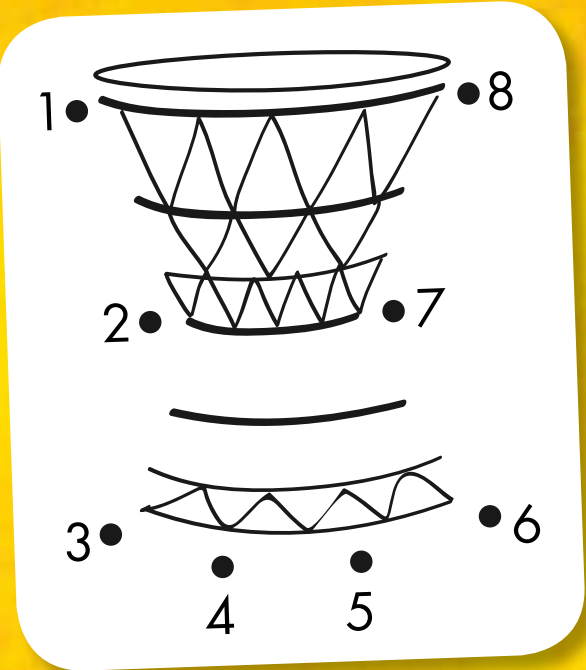

loud



quiet





What are you doing?

I'm dancing!



WELCOME TO OUR WORLD

AMERICAN ENGLISH

For ISBNs, more information, or to order, please visit NGL.Cengage.com/ourworldtours or contact your local representative.

MATERIALS FOR ALL YOUNG LEARNERS

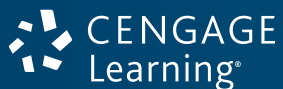
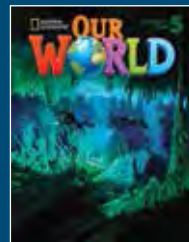
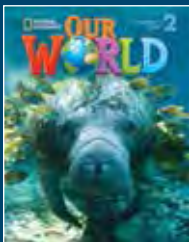
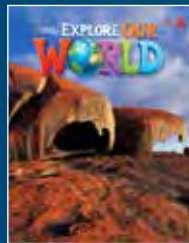

ISBN-13: 978-13052-67602
ISBN-10: 13052-67605



OCT/14

9 781305 267602